

Items Supplied >

1 - RIGHT MUFFLER ASSEMBLY
1 - LEFT MUFFLER ASSEMBLY
2 - MUFFLER CLAMPS (268-62)
2 - M8 NYLOCK NUTS
2 - M8 FLAT WASHERS

Application(s) >

HONDA GL1800 01-11

Instruction Manual >

1215

Page 1 of 2

PRIOR TO INSTALLATION, MAKE SURE YOUR STOCK GASKETS ARE IN GOOD SHAPE. IF YOU HAVE ANY DOUBTS AS TO THEIR CONDITION, REPLACE THEM.

1. Remove the stock muffler assemblies by first removing the M8 bolts, flat washers and nuts from the frame mounts above the muffler bodies. Retain mounting hardware for later use.
2. Loosen the muffler clamps on both sides (see Figure 1) and slide the stock muffler assemblies toward the rear of the motorcycle to remove. (Do not remove heatshields).
3. Remove the stock exhaust gaskets from the original mufflers and place them into the supplied mufflers. Remove the rubber tab grommets from the front of the stock mufflers and place them on the tabs located on front of the supplied muffler assemblies (see Figure 2 and 3).
4. Slide the supplied clamps onto the mufflers and orient them as shown in Figure 2.
5. Install the mufflers onto the stock headpipes (position the mount bracket towards the inside of the frame) while aligning the heatshield support tabs with the stock heatshield cover (see Figure 3). To do this, gently slide the muffler forward while slightly squeezing the heatshield together to align the tabs with the heatshield clips. There will be a uniform gap between the heatshield and muffler when properly installed.
6. Insert the stock bolt thru the stock washer, frame mount, muffler mount bracket, supplied M8 washer and into the supplied M8 nylock nut; do not tighten at this time. (See Figure 2).
7. Make sure the front of the muffler bodies are still aligned with the heatshields. From the rear, rotate the mufflers as needed so they are level with the ground and parallel with each other. Tighten the rear mount bolts/nuts to factory specifications.
8. Tighten the muffler clamps (NOTE: If the muffler clamps are slid to far up the muffler or past the two slots, the clamps will not tighten the mufflers properly).
9. NOTE: The exhaust tips may be loosened and oriented to four different positions for distinct visual effects; to do so remove the (2) buttonhead screws securing each tip and rotate tips to desired position and align holes. Insert buttonhead screws and be sure to properly tighten upon reinstallation.

Before starting your engine remove all fingerprints from chrome with a quality wax or chrome polish. Failure to do so can cause chrome discoloration.

*** Cobra® recommends you always wear a helmet while riding. Please never operate your motorcycle while under the influence of alcohol and/or drugs. Enjoy the new look of your motorcycle and please ride safely.**

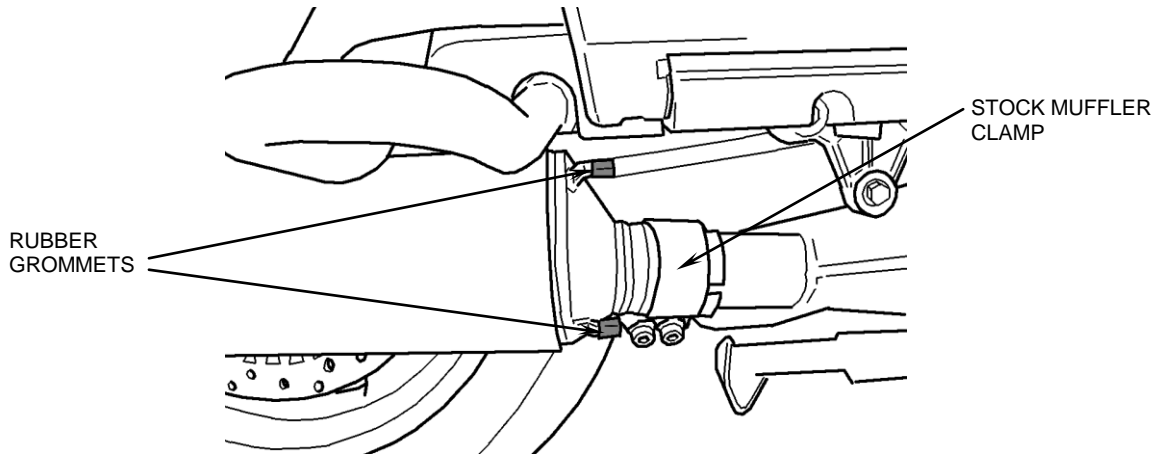
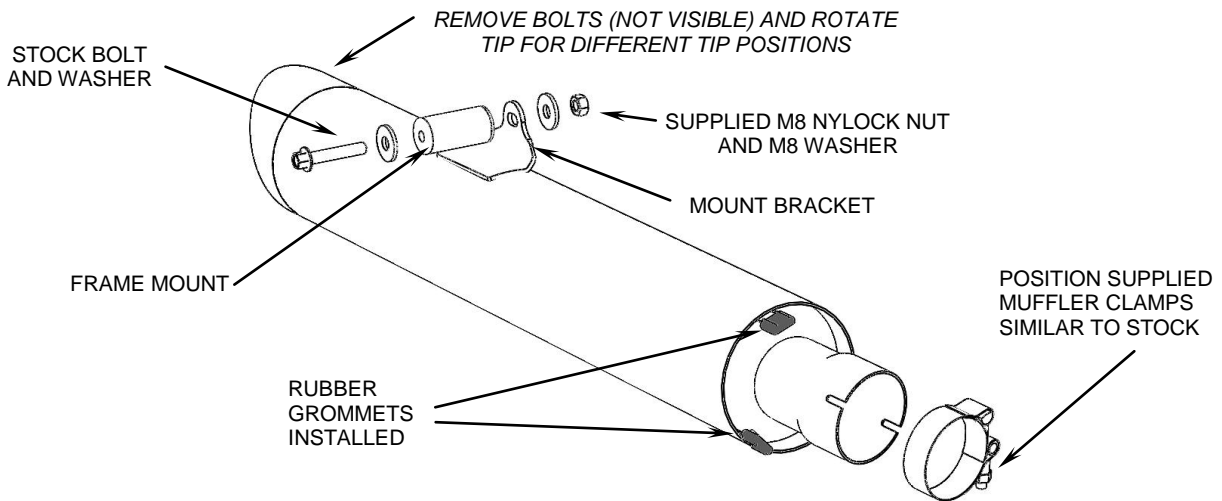

FIGURE 1

RIGHT SIDE SHOWN

(HEAT SHIELD REMOVED FOR CLARITY, DO NOT REMOVE HEATSHIELD)



RIGHT SIDE SHOWN

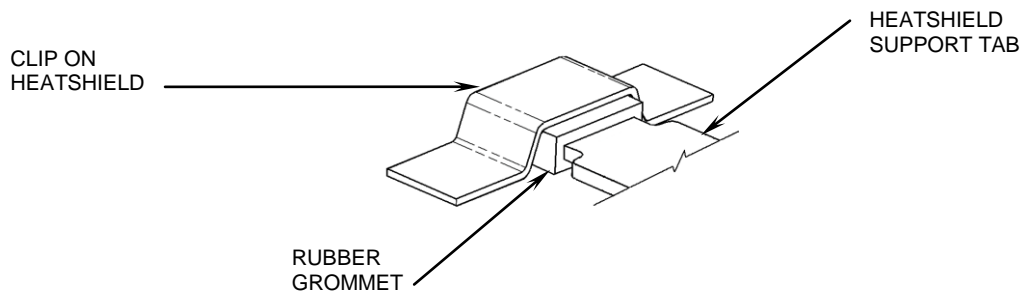

FIGURE 3