

# INSTRUCTIONS

## 5-SPEED KICKER KIT

FITS 5-SPEED BIG TWIN MODELS 1982-UP

**FIGURE 1**

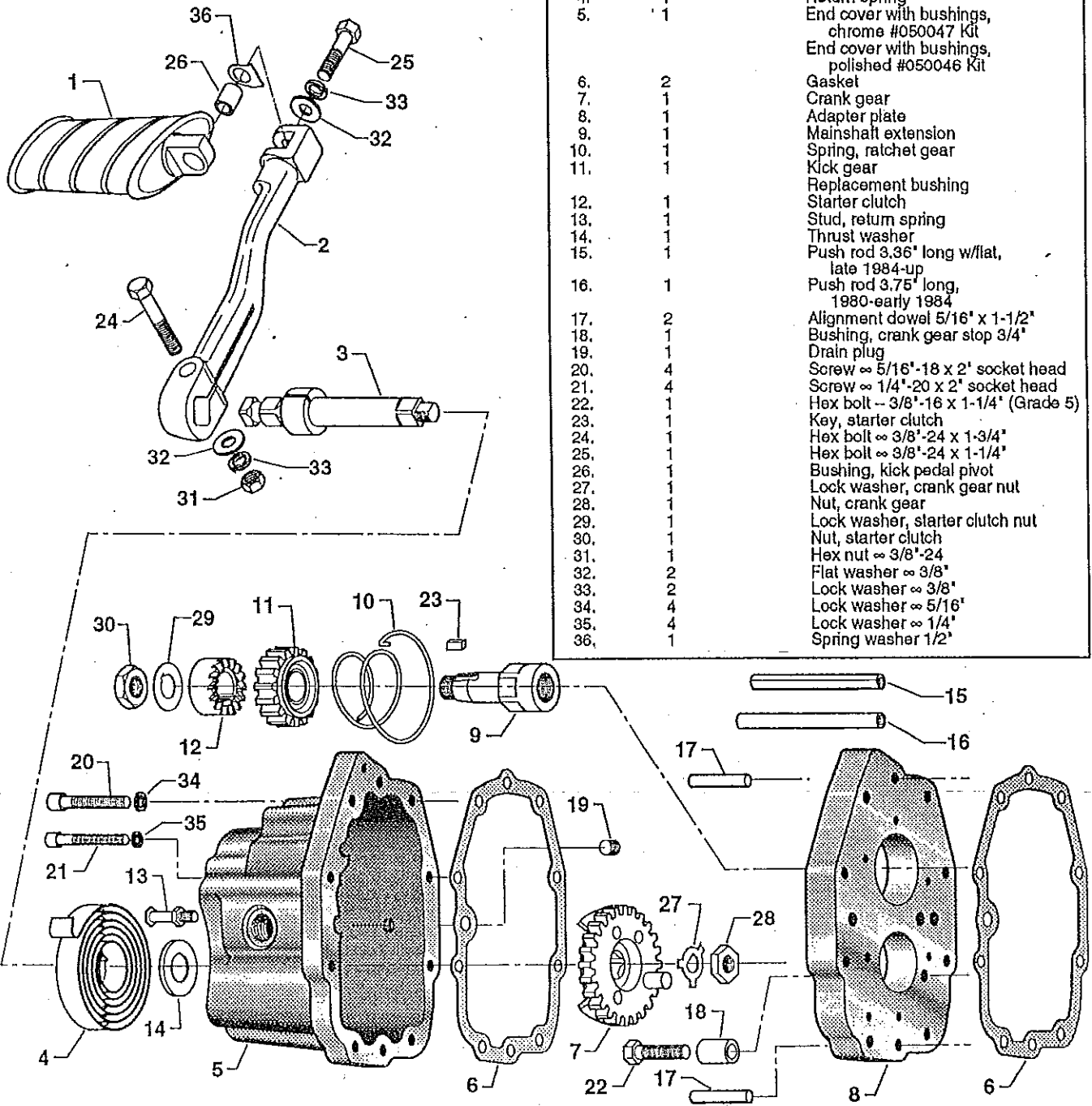

KIT NUMBER 911046/900790

**CONTENTS:**

INDEX	QTY	DESCRIPTION
1.	1	Kick pedal
2.	1	Kick arm
3.	1	Kicker shaft
4.	1	Return spring
5.	1	End cover with bushings, chrome #050047 Kit
		End cover with bushings, polished #050046 Kit
6.	2	Gasket
7.	1	Crank gear
8.	1	Adapter plate
9.	1	Mainshaft extension
10.	1	Spring, ratchet gear
11.	1	Kick gear
		Replacement bushing
12.	1	Starter clutch
13.	1	Stud, return spring
14.	1	Thrust washer
15.	1	Push rod 3.36" long w/flat, late 1984-up
16.	1	Push rod 3.75" long, 1980-early 1984
17.	2	Alignment dowel 5/16" x 1-1/2"
18.	1	Bushing, crank gear stop 3/4"
19.	1	Drain plug
20.	4	Screw ∞ 5/16"-18 x 2" socket head
21.	4	Screw ∞ 1/4"-20 x 2" socket head
22.	1	Hex bolt - 3/8"-16 x 1-1/4" (Grade 5)
23.	1	Key, starter clutch
24.	1	Hex bolt ∞ 3/8"-24 x 1-3/4"
25.	1	Hex bolt ∞ 3/8"-24 x 1-1/4"
26.	1	Bushing, kick pedal pivot
27.	1	Lock washer, crank gear nut
28.	1	Nut, crank gear
29.	1	Lock washer, starter clutch nut
30.	1	Nut, starter clutch
31.	1	Hex nut ∞ 3/8"-24
32.	2	Flat washer ∞ 3/8"
33.	2	Lock washer ∞ 3/8"
34.	4	Lock washer ∞ 5/16"
35.	4	Lock washer ∞ 1/4"
36.	1	Spring washer 1/2"

# 5-SPEED KICKER KIT

**PART NUMBER: 911046/900790 --- FITS 5-SPEED BIG TWIN MODELS 1982-UP**

## CAUTION:

- 1) **READ COMPLETELY PRIOR TO INSTALLATION.**
- 2) **ALL PARTS SHOULD BE INSPECTED PRIOR TO INSTALLATION FOR PROPER FIT AND FUNCTION BY A QUALIFIED MECHANIC. INSTALLATION MUST BE IN ACCORDANCE WITH THE ORIGINAL EQUIPMENT MANUFACTURER'S (OEM) SERVICE MANUAL BY A QUALIFIED MECHANIC.**
- 3) **SECURE MOTORCYCLE ON A SUITABLE SUPPORT SO THAT IT IS CLEAR OF THE SIDE STAND.**

## **INSTALLATION PROCEDURES:**

### ALL MODELS

1. Remove drain plug and drain oil from the transmission. Loosen and remove the exhaust pipes. Remove the transmission dip stick. Remove clutch plate cover on the left side of the motor.
2. Remove the transmission side cover. On 1982-1986 5-speed models disconnect the clutch cable from the clutch release lever. On 1987-up models remove the circlip retaining the ramp and ball assembly. Lift off the top ramp and remove the three ball bearings. Rotate the cable coupling and remove top ramp.

The end cover can now be screwed off of the clutch cable.

3. If you purchased the easy installation tool MCS #519732 skip to step four (4). If you did not purchase the installation tool proceed as follows:

A. Disassemble the transmission as outlined in the mainshaft/countershaft removal section of the service manual for your model.

B. See **FIGURE 1**. Press the bearings out of the stock side door and re-install in the adapter plate (8) (Install new bearings if yours show signs of wear).

C. Re-assemble mainshaft/countershaft and adapter plate using two longer (5/16" x 1-1/2") dowels (17) and 1 gasket (6), as specified in the service manual. Proceed to step seven (7).

4. If you purchased the easy installation tool proceed as follows:

A. Remove the nuts and spacers on the mainshaft and countershaft.

B. Place the side door removal tool on the door using the end cover bolt holes. By alternately turning the jack screws for the mainshaft and countershaft, work the end door off the shafts. Use only 1/2 turns at a time to keep a straight pull on the end door until it is removed.

(continued on Page 3)

# 5-SPEED KICKER KIT

**PART NUMBER: 911046/900790 -- FITS 5-SPEED BIG TWIN MODELS 1982-UP**

C. Once the end door is off remove the circlips and press out the bearings. Re-install these parts in the adapter plate (8) (use new bearings if yours are worn or damaged).

5. See **FIGURE 1**. Replace the two alignment dowels in the transmission case with the longer (5/16" x 1-1/2") dowels (17) in the kit. Do not try to remove the shifter fork shaft at the top of the side opening.

6. Install a new gasket (6) on the transmission case. Place the adapter plate over the mainshaft, countershaft and alignment dowels. Install the two hex lugs on the two shaft ends. **CAUTION: When installing adapter plate, make sure plate presses onto alignment dowels smoothly without binding so as to prevent damage to bearings or adapter plate.** Using alternating 1/2 turns, press the adapter plate into place. Do not use the stock nylon nuts for this purpose.

7. Screw the mainshaft extension (9) onto the shaft (**WARNING:** Red Loctite or equivalent thread locking compound must be used). Do not replace the original mainshaft spacer. Torque the extension to specs (27-33 ft. lbs.).

8. Install the crank gear stop bolt (22) and bushing (18).

9. Measure the kick gear spring (10) to make sure it is 1-3/8" in height, adjust as necessary. Install the spring over the mainshaft extension and put the hook in one of the holes of the adapter plate.

10. Pre-lube the kick gear bushing(11) and extension shaft (9) with engine oil. Place the kick gear on the extension shaft (ratchet teeth out) and locate the small end of the spring on the gear shoulder. Kick gear bushing must be loose enough on mainshaft extension for gear

to slide freely under the force of the compressed spring. (**WARNING:** Kick gear (11) is supplied with a high-performance self-lubricating bushing — do not sand, ream or in any way attempt to modify and/or remove the grey inner coating. Replace with MCS'S only). Install key (23) in the shaft keyway and put the starter clutch (12) on end of the shaft. Place the lock washer (29) and nut (30) on the end of the shaft and tighten to 18-20 ft. lbs. Bend lock washer tab to lock nut.

11. Replace the throw-out bearing and rod in the mainshaft.

12. Pre-1987 models will have to be updated at this time. You will need a 1987-up clutch cable and release mechanism for your model.

**Conversion clutch cables for 1982-1986**

## Models

FXR, FXRS, FXRT  
(OEM 38606-87A)

FXLR (OEM 36753-87A)

FLT, FLHT, FXST, FLST.  
(OEM 38607-87A)

**Conversion clutch actuator for 1982-1986**

ALL MODELS MCS #555555

**Conversion clutch adjuster for late 1990-up**

ALL MODELS MCS #517447

13. Place the clutch cable end through the new end cover threaded hole and screw the cover onto the cable. Put the cable coupler on the end of the cable. Rotate the stud end of the coupler until the flat side fits into the hook on the top of the ramp of the ball and ramp assembly. Drop the lower ramp into place in the end cover. Locate the retaining finger in the slot in the cover.

(continued Page 4)

Place a 3/8" bearing in each of the depressions and install the top ramp. Secure the assembly to the end cover with the circlip. Check the cable coupler-to-kicker cover clearance at this time. Operate the clutch lever several times while observing the ball and ramp mechanism from the inside. On some models, minor interference may occur. If necessary, remove material from the cover (a rotary file works well) to achieve smooth clutch operation.

14. Assemble the kicker shaft (3), thrust washer (14), crank gear (7), lock washer (27), nut (28) and stud (13) in the end cover (5), as explained in the service manual for a 4-speed kick start. (Coat the inside of the bushing, O-ring and shaft with oil to ease installation).

15. **IMPORTANT!** 1979-1986 models require a 3/4" long spacer in the shifter shaft hole.  
**WARNING!** Failure to install spacer on 1979-1986 models may result in transmission failure.

Loosen and remove the clutch adjustment screw\*. Remove and discard the left pushrod. On 1979-1986 models, install a 3/4" long spacer in the shifter shaft hole in the adapter plate to prevent movement of the shaft. Install the kicker cover gasket (6) and the cover (5) on the alignment dowels. Check to see that the lug on the kicker gear (7) is to the right of the kicker gear stop (22 and 18). Insert the cover bolts (20 and 21) with lock washers (34 and 35). Tighten bolts securely.

16. Place kick start return spring (4) on the shaft (3) and hook the end to the return spring stud (13). Install the kick start arm (2) to the shaft and secure with bolt (24), washer (32), lock washer (33) and nut (31). Attach pedal (1) to the arm with bushing (26), spring washer (36), washers (32 and 33) and bolt (25). Tighten everything up. Kick the motor over to check for correct operation.

17. Replace the drain plug and fill the transmission with oil. **NOTE:** Our kicker covers use CSI dipstick #500631 or 1987-up stock OEM dipstick. Pre-1987 dipsticks will not work as the threads are different. **NOTE:** With the motorcycle level, fill the transmission to the full mark with the dip stick resting on top of the threads — do not screw the dip stick into the cover to check oil level (as specified in Harley-Davidson® service bulletin No. M-991 dated March 30, 1990). Let motorcycle set for several minutes to allow oil to migrate from the kicker cover into the transmission — recheck oil level. Repeat this procedure as necessary to insure proper oil level.

**IMPORTANT!**

Transmission oil level is critical for proper operation of this kit. Oil fill procedures outlined above must be observed by all parties, owners, mechanics or service establishments performing periodic oil level inspections, transmission oil changes, or any transmission service. Owner/operator should retain these instructions for future reference.

**WARNING!**

Failure to maintain proper oil level can result in transmission failure.

18. Replace the exhaust pipes. Slight adjustment of exhaust mounting bracket may be required.

19. Install the clutch release rod extension (15 for late 1984-up) or (16 for 1980-early 1984) in the left side of the mainshaft. Replace the clutch adjusting screw\* and jam nut. Adjust the clutch for proper operation. Replace the clutch plate cover.

\*NOTE: Late 1990 and later models will need to use MCS #517447 adjusting screw which replaces OEM 37357-84.