

Instruction 510-0815
12-21-20

Version 1

© 2020

by S&S® Cycle, Inc.

All rights reserved.

Printed in the U.S.A.

S&S® Cycle, Inc.

14025 Cty Hwy G
Viola, Wisconsin 54664

Phone: 608-627-1497

Technical Service Email: sstech@sscycle.com

Website: www.sscycle.com



Installation Instructions: S&S Qualifier 2:1 Performance Exhaust System for 2019-'21 Royal Enfield® 650 Twins—Race Only

DISCLAIMER:

Many S&S parts are designed for high performance, closed course, racing applications and are intended for the very experienced rider only. The installation of S&S parts may void or adversely affect your factory warranty. In addition such installation and use may violate certain federal, state, and local laws, rules and ordinances as well as other laws when used on motor vehicles used on public highways. Always check federal, state, and local laws before modifying your motorcycle. It is the sole and exclusive responsibility of the user to determine the suitability of the product for his or her use, and the user shall assume all legal, personal injury risk and liability and all other obligations, duties, and risks associated therewith.

The name Royal Enfield® is used in reference only. S&S Cycle is not associated with Royal Enfield and we in no way are implying that any of S&S Cycle's products are original equipment parts.

DISCLAIMER: FOR CLOSED COURSE COMPETITION USE ONLY. NOT INTENDED FOR STREET USE. LEGAL IN CALIFORNIA ONLY FOR RACING VEHICLES WHICH MAY NEVER BE USED, OR REGISTERED OR LICENSED FOR USE, UPON A HIGHWAY. NOT LEGAL FOR SALE OR USE NATIONWIDE ON ANY FEDERAL POLLUTION CONTROLLED MOTOR VEHICLE UNDER THE CLEAN AIR ACT.

SAFE INSTALLATION AND OPERATION RULES:

Before installing your new S&S part, it is your responsibility to read and follow the installation and maintenance procedures in these instructions and follow the basic rules below for your personal safety.

- Gasoline is extremely flammable and explosive under certain conditions and toxic when breathed. Do not smoke. Perform installation in a well ventilated area away from open flames or sparks.
- If motorcycle has been running, wait until engine and exhaust pipes have cooled down to avoid getting burned before performing any installation steps.
- Before performing any installation steps, disconnect battery to eliminate potential sparks and inadvertent engagement of starter while working on electrical components.
- Read instructions thoroughly and carefully so all procedures are completely understood before performing any installation steps. Contact S&S with any questions you may have if any steps are unclear or any abnormalities occur during installation or operation of motorcycle with an S&S part on it.
- Consult an appropriate service manual for your motorcycle for correct disassembly and reassembly procedures for any parts that need to be removed to facilitate installation.
- Use good judgment when performing installation and operating motorcycle. Good judgment begins with a clear head. Don't let alcohol, drugs or fatigue impair your judgment. Start installation when you are fresh.
- Be sure all federal, state and local laws are obeyed with the installation.
- For optimum performance and safety and to minimize potential damage to carb or other components, use all mounting hardware that is provided and follow all installation instructions.
- Motorcycle exhaust fumes are toxic and poisonous and must not be breathed. Run motorcycle in a well ventilated area where fumes can dissipate.

IMPORTANT NOTICE:

Statements in this instruction sheet preceded by the following words are of special significance.



WARNING

Means there is the possibility of injury to yourself or others.



CAUTION

Means there is the possibility of damage to the part or motorcycle.

NOTE

Other information of particular importance has been placed in italic type.

S&S recommends you take special notice of these items.

WARRANTY:

All S&S parts are guaranteed to the original purchaser to be free of manufacturing defects in materials and workmanship for a period of twenty-four (24) months from the date of purchase. Merchandise that fails to conform to these conditions will be repaired or replaced at S&S's option if the parts are returned to us by the purchaser within the 24 month warranty period or within 10 days thereafter.

In the event warranty service is required, the original purchaser must call or write S&S immediately with the problem. Some problems can be rectified by a telephone call and need no further course of action.

A part that is suspect of being defective must not be replaced by a Dealer without prior authorization from S&S. If it is deemed necessary for S&S to make an evaluation to determine whether the part was defective, a return authorization number must be obtained from S&S. The parts must be packaged properly so as to not cause further damage and be returned prepaid to S&S with a copy of the original invoice of purchase and a detailed letter outlining the nature of the problem, how the part was used and the circumstances at the time of failure. If after an evaluation has been made by S&S and the part was found to be defective, repair, replacement or refund will be granted.

ADDITIONAL WARRANTY PROVISIONS:

- (1) S&S shall have no obligation in the event an S&S part is modified by any other person or organization.
- (2) S&S shall have no obligation if an S&S part becomes defective in whole or in part as a result of improper installation, improper maintenance, improper use, abnormal operation, or any other misuse or mistreatment of the S&S part.
- (3) S&S shall not be liable for any consequential or incidental damages resulting from the failure of an S&S part, the breach of any warranties, the failure to deliver, delay in delivery, delivery in non-conforming condition, or for any other breach of contract or duty between S&S and a customer.

Stock Muffler Removal:

1. Remove screw from muffler inlet heat shield and slide heat shield forward to remove. **See Picture 1.**
2. Loosen clamp securing muffler to header.
3. Loosen and remove bolt and nut from muffler mount bracket. Put aside for re-use.
4. Remove Muffler from head pipe.
5. Remove exhaust pipe mount bracket bolt.
6. Disconnect oxygen sensor connector
7. Loosen and remove exhaust port nuts.
8. Remove header. Remove oxygen sensor from header. Put aside for re-use
9. Repeat procedure for opposite side muffler.



Picture 1

New Muffler Installation:

10. Apply a small amount of anti-seize to oxygen sensor threads, install oxygen sensors into headers.
11. Install header into cylinder head port, install exhaust flange nuts loosely onto studs. Repeat for other cylinder.
12. Install muffler support bracket (3) onto muffler.
13. Slide muffler onto midpipe. Install bolt through muffler bracket and tighten to 15-18 lb./ft.
14. Install muffler mount springs and tighten muffler bracket hardware to 15-18 lb./ft.
15. Tighten exhaust port flange nuts to 22 lb./ft.

16. Before operating motorcycle, clean head pipes and muffler with soap and water or window cleaner. Any grease or oil will permanently burn onto pipes. Dry thoroughly.
17. Check all mounting hardware to be sure it is tight before and after first operation of motorcycle. Periodically, check the tightness of all mounting hardware.

Replacement Parts

- | | |
|---|----------|
| 1. Header Pipe..... | 551-1543 |
| 2. Muffler (see next page for breakdown)..... | 551-1544 |
| 3. Bracket..... | 551-1471 |
| 4. Spring, Exhaust, Long, w/ Swivel Hooks | LFT-0477 |
| 5. Screw, BHC, M8 x 1.25 x 14mm, Stainless Steel..... | 500-1354 |
| 6. Nut, Flanged, M8, Stainless Steel | 500-1355 |

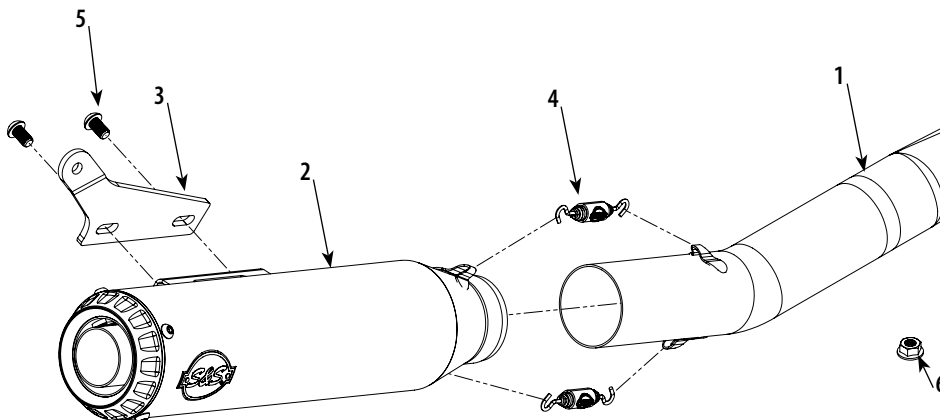
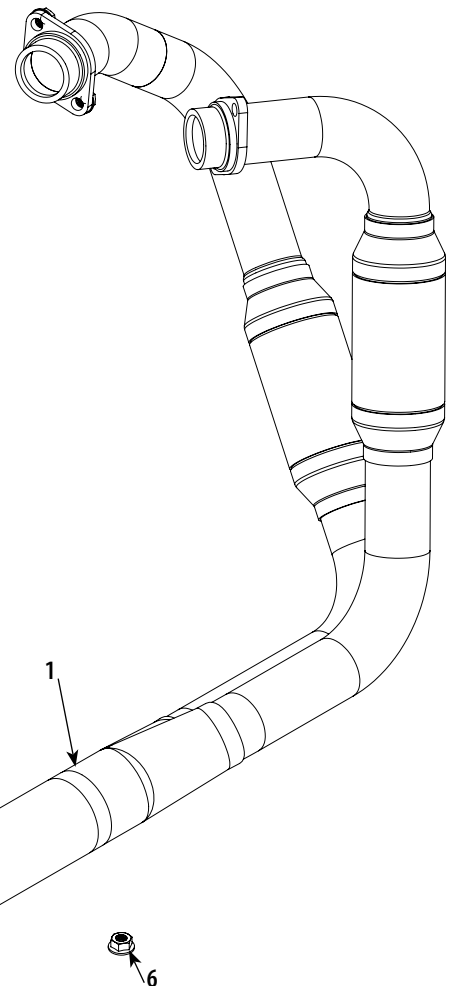

Replacement Parts

- 7. Muffler Body..... 551-1526
- 8. Insulation.....551-1167
- 9. Sheet, 8.5" x 12", HD Wool, Bristol Core500-0698
- 10. Baffle 551-1480
- 11. End cap..... 551-1481
- 12. Insert 551-1478
- 13. Screw, BSHC, M6 x 1.0 x 8mm, Steel, Zinc LFT-0804
- 14. Screw, BHC, High Temp Lock Patch, M6 x 22, Stainless Steel.....500-1353

