

Congratulations, you have purchased the finest exhaust system available for your motorcycle. Your Vance & Hines exhaust is designed and crafted for performance, quality, and style. Please follow the instructions below, check exhaust system for missing or damaged parts and if you need any assistance please contact our technical support line (562) 921-7461.

## PARTS LIST

ITEM NO.	DESCRIPTION	QTY.
1	RIGHT MUFFLER	1
2	LEFT MUFFLER	1
3	MOUNTING BRACKET RT.	1
4	MOUNTING BRACKET LT.	1
6	FHS 5/16-18 X 5/8"	2
7	DOGBONE NUTPLATE	2

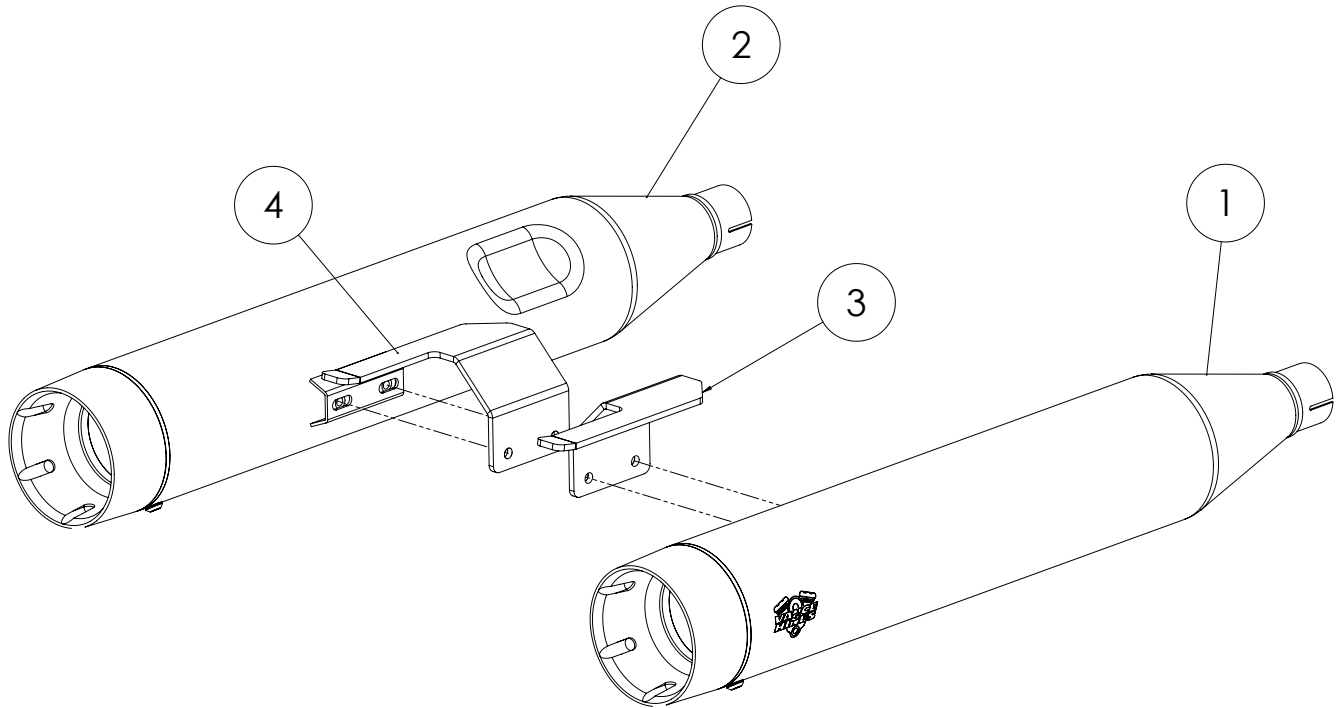

## HARDWARE

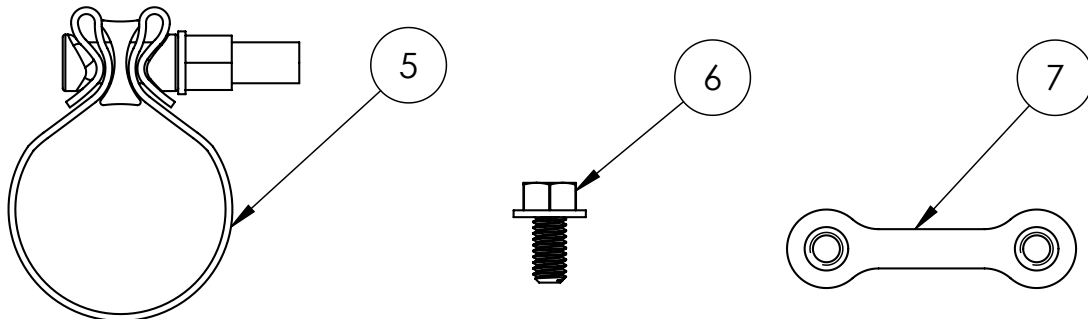

\*NOT ACTUAL SIZE

## TOOLS REQUIRED

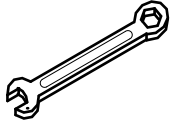

Combination Wrenches:  
1/2", 9/16"

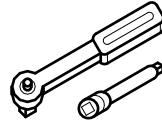

3/8" Drive Ratchet with  
4" extension, 1/2 Std.,  
9/16" deep well sockets

## STOCK EXHAUST SYSTEM REMOVAL

1. Remove both left and right saddlebags and set them aside.
2. Loosen the bolt from the pinch clamp on the front end of each muffler.
3. Remove the two 5/16" bolts that mount the muffler to the saddlebag supports. Repeat this step on the opposite muffler.
4. Remove the stock mufflers and set them aside. **NOTE:** It may be necessary to use a penetrating lubricant to loosen the muffler from the head pipe.
5. Leaving the grommets in place, remove the stock mounting brackets from the rubber grommets located on the saddle supports. **NOTE:** Inspect the grommets to verify that they are in good condition, if the grommets are damaged they will need to be replaced.

## VANCE & HINES EXHAUST INSTALLATION

1. Install the muffler mount brackets into grommets. Mount bracket (3) goes on the right side and mount bracket (4) goes on the left side.
2. Install Torca clamps (5) onto each muffler inlet so that the Torca clamp bolt is to the inside and the nut is facing down. (Figure 1)
3. Slide right side muffler on. **NOTE:** Dent will be on the inside.
4. Slide nut plates inside the tent brackets welded to backside of the mufflers bodies and attach the muffler to the muffler support bracket using two 5/16"-18 flange bolts (6). Finger tighten only. (Figure 2)
5. Repeat installation procedure for opposite muffler.
6. Align mufflers bodies then torque the Torca band clamps to 40-44 ft. lbs. Slide the muffler support bracket as far as possible before tightening the two flange bolts. After alignment torque the bolts to 18 ft. lbs.
7. Replace the saddlebags.
8. After installation and before starting the motorcycle, completely clean chrome mufflers with cleaning solvent and a clean, soft cloth that will not leave any residue. Before starting the motorcycle with black mufflers thoroughly clean them with warm soapy water and a soft cloth. **NOTE:** Any residue, oil, or fingerprints will stain the chrome when the metal heats up.
9. Be sure to tighten all hardware before starting your motorcycle.
10. **IMPORTANT:** After test ride let pipes cool down and retorque muffler band clamps.

## EXHAUST CARE

1. When installing a new set of chrome pipes, make sure your hands are clean and free of oil. After installation, thoroughly clean pipes with a soft cloth and cleaning solvent that will leave no residue (chrome wax/polish, glass cleasner, alcohol, ammonia, etc...) before starting the motorcycle.
2. Avoid long periods of idling as this can cause discoloration.
3. Intake leaks can cause the engine to run lean and overheat, this could lead to discoloration.
4. Make sure there are no exhaust leaks at the junction of the exhaust pipes and cylinder head. We recommend replacing gaskets if they are worn.

## EXHAUST CARE (BLACK)

1. When installing a new set of black pipes, make sure your hands are clean and free of oil. After installation, thoroughly clean pipes with warm soapy water and a soft cloth. Dry with a clean towel to remove any residue before starting the motorcycle. Do NOT use anything abrasive to clean the pipes.
2. Avoid long periods of idling as this can cause discoloration.
3. Intake leaks can cause the engine to run lean and overheat, this could lead to discoloration.
4. Make sure there are no exhaust leaks at the junction of the exhaust pipes and the cylinder head. We recommend replacing gaskets if they are worn.

**FIGURE 1**

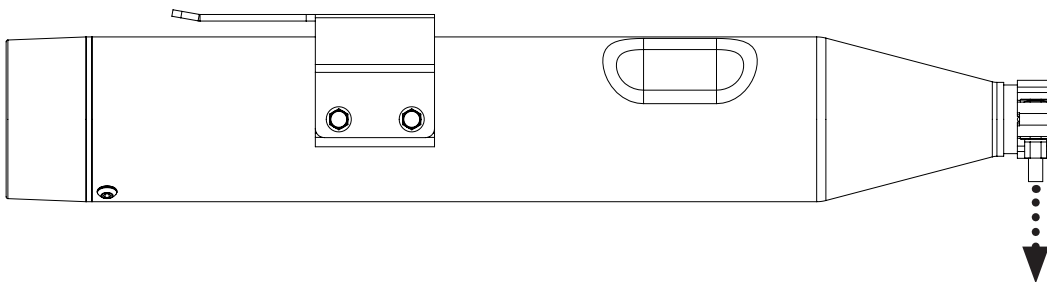

**FIGURE 2 (**

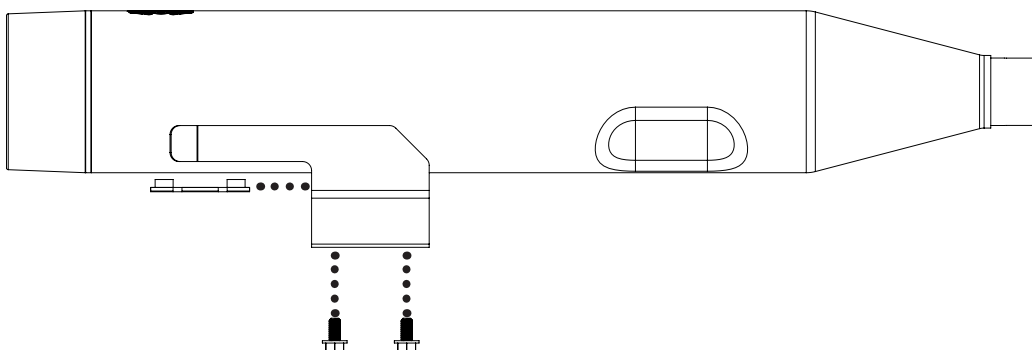

Emissions Notice:

In California, in order to meet Air Resources Board emissions requirements, certain aftermarket part applications have been identified as replacements, and others have received ARB Executive Orders. All other emissions related aftermarket parts are for competition use only. A list of replacement parts and EO parts, and corresponding fitment is provided at [vanceandhines.com/california](http://vanceandhines.com/california).

Warranty:

All Vance & Hines products are warranted against defects in material and workmanship for a period of 90 days. This warranty does not cover discoloration or rust. This warranty shall be limited to the repair or replacement of the product, which may be proven defective under normal use. Vance & Hines will not warranty any system that has been abused, misused, improperly installed or modified.

Dealers or distributors are not authorized to make dispositions binding upon Vance & Hines. Vance & Hines will not be responsible for any labor charges incurred in removing or replacing any system under warranty. A return authorization number and a copy of the original purchase invoice must accompany all returns. Parts returned without a return authorization may be refused.

13861 ROSECRANS AVENUE / SANTA FE SPRINGS, CA 90670

SALES: (562) 921-5388

TECHNICAL: (562) 926-5291

FAX: (562) 802-0110